

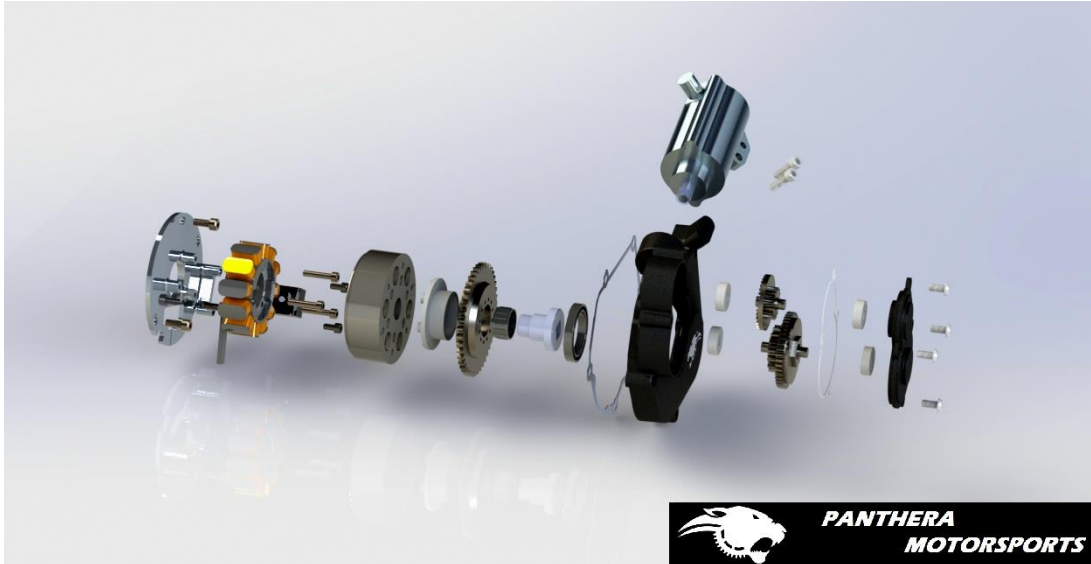

PANTHERA MOTORSPORTS

YZ250-YZ250X Electric starter - Installation guide

List of Panthera parts you need



- 1- Panthera starter electric motor
- 2- Lighting Stator*
- 3- Panthera flywheel*
- 4- High strength flywheel adapter
- 5- Main starter gear/clutch
- 6- Needle bearing
- 7- Bolting nut and bearing holder
- 8- Panthera starter cover and cap
- 9- Sealed ball bearing
- 10- Crown starter gear
- 11- Intermediate torque limiter gear
- 12- Starter relay
- 13- Current rectifier*
- 14- Battery box
- 15- Wiring harness
- 16- Starter button
- 17- Carbon fiber shield*

*Optional components, only if these options were selected in the kit.



PANTHERA MOTORSPORTS

YZ250-YZ250X Electric starter - Installation guide

List of tools you need

- 1- 3/8 drive Socket ranch
- 2- Socket ranch extension
- 3- 10mm socket
- 4- Phillips drive bit
- 5- Yamaha M27x1 flywheel puller
- 6- 6mm allen drive bit
- 7- 5mm allen drive bit
- 8- 4mm allen drive bit
- 9- 60-150 in-lb torque wrench
- 10- ½ drive torque wrench

Security concerns

Engine assembly must always be accomplished by a qualified mechanic.

Use the proper tools for every operation and always wear the proper personal protective equipment (glass, gloves, etc.)

The parts sold by Panthera Motorsports are often machined parts and are at risk of having sharp edges. Always handle with care.



PANTHERA MOTORSPORTS

YZ250-YZ250X Electric starter - Installation guide

Original parts disassembly

In order to make the wiring installation, the motorcycle seat and fuel tank have to be removed.

Seat removal

With a 10mm socket, remove the two seat bolts on each side and remove the seat.

Fuel tank removal

Undo the rubber link between the chassis and the tank. With an extension and a 10mm socket, remove the two bolts holding the tank to the chassis as well as the two bolts between the tank side covers and the radiator guards.

Making sure the fuel valve is closed, slide off the collar and remove the fuel line, using a rag to collect the fuel drop.

Flywheel removal (for starter kit without charging system)



With a Philips drive bit, remove the 5 flywheel cover bolts and cover.

With a M27x1 flywheel puller, remove the original flywheel.

Clean the stator and stator case internal so that no dirt remains.



PANTHERA MOTORSPORTS

YZ250-YZ250X Electric starter - Installation guide

Flywheel and stator removal (for starter kit with charging system)



With a philips drive bit, remove the 5 flywheel cover bolts and cover.

With a M27x1 flywheel puller, remove the original flywheel.

Unplug the stator connector located between the two radiators.

With a philips drive bit, remove the 3 stator bolts and the stator.

Clean the case internal so that no dirt remains.

Panthera system installation

Battery box and wiring installation



Install the battery box inside the airbox and bolt it to the subframe holes available. Use the 2 supplied M8 socket bolt and spacer and torque to 110 in-lb.



PANTHERA MOTORSPORTS

YZ250-YZ250X Electric starter - Installation guide

Run the wiring loom between the airbox and under the chassis shock tower. The plastic of the airbox is often very sharp, it is suggested to file the sharp edge of the plastic to ensure wires don't get cut over time.



Run the wires along the frame and secure with zip ties. The two power cables (black and red) are to follow down the clutch cable towards the starter cover.

Install the starter button to the handlebars with the supplied camp and connect to the harness.

[Panthera stator installation \(for starter kit with charging system\)](#)

Place the new stator inside the casing and ensure that the rubber boot is properly sliding in its location. Proper seat of the rubber is important as the starter housing will contain oil.

Bolt the stator in place with the 3 supplied button head screws using an allen 4mm drive bit. Make sure the timing mark is aligned and torque to 70 in-lb.

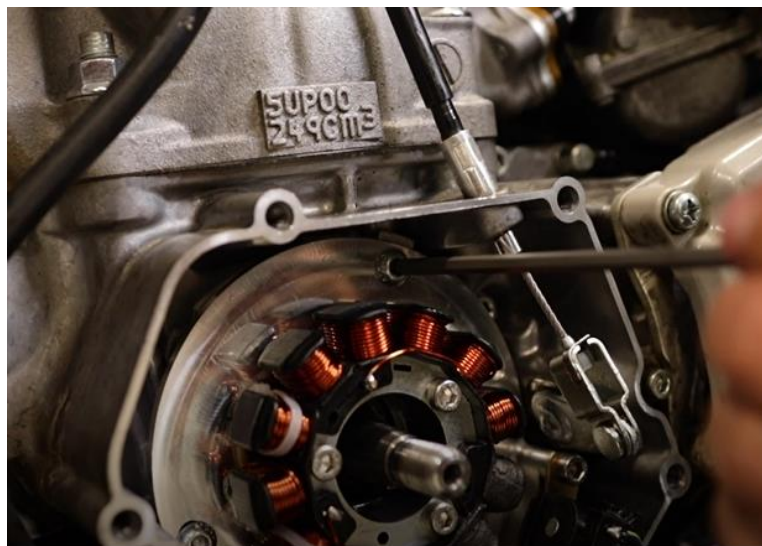



PANTHERA MOTORSPORTS

YZ250-YZ250X Electric starter - Installation guide

Connect the stator 6 pins connector to the bike harness.

Connect the charging coil 2 pins connector to the bike harness

Flywheel and main gear installation (for starter kit without charging system)

To run the starter assembly while keeping the original flywheel and stator, it is required to change the flywheel heart for the new supplied heart with a starter coupling.

Follow the specific flywheel heart replacement instruction supplied with your new flywheel heart.



Clean the inside of the flywheel of any chip or dirt and prepare for installation.

Slide the flywheel on the crankshaft and assure the keyway aligns with the woodruff key on the crank.

Place the main ring gear on the flywheel by rotating it clockwise while you push it on.

Put the needle bearing in the middle and insert the bolting unit.

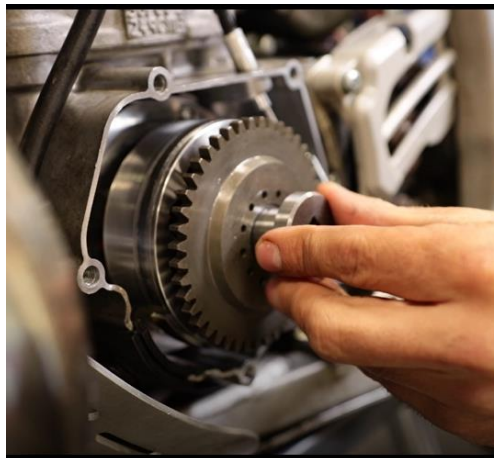



PANTHERA MOTORSPORTS

YZ250-YZ250X Electric starter - Installation guide

Using the gear holding tool supplied and a 1/2in torque wrench, torque the bolting unit to 40 ft-lb.

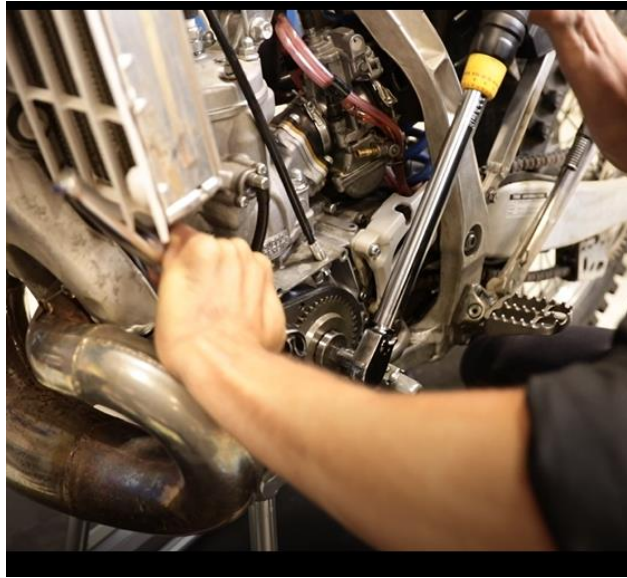

Make sure the main gear is still rotation freely clockwise and locking counterclockwise.

To ensure proper installation, measure the distance of the ring gear face to the gasket surface on the engine. Some cranks can be out of specifications or have been re-machined due to previous damages to crankshaft taper. If the flywheel doesn't sit at proper distance, it could damage the stator or prevent the starter gears from spinning. Push the gear toward the engine as much as it can and measure distance to engine gasket surface. The tolerance for the gear distance is 19.0 to 20.8mm.

Flywheel and main gear installation (for starter kit with charging system)

Slide the Panthera flywheel on the crankshaft and assure the keyway aligns with the woodruff key on the crank. Verify that the pick up coil to trigger bump distance is between 0.25-0.40mm. Bend the pick up coil bracket if needed to reach that value.

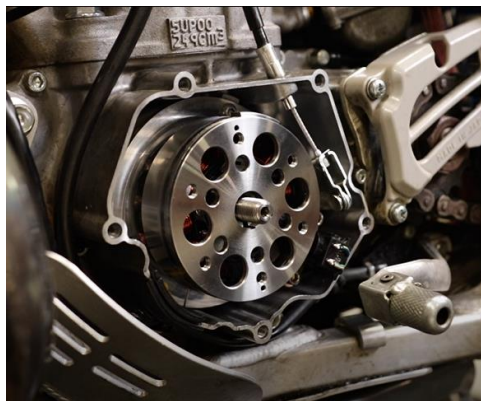

It is a good practice to temporarily bolt the flywheel and make sure you have a spark while kicking. If not, check for bad connection. Then remove the nut.



PANTHERA MOTORSPORTS

YZ250-YZ250X Electric starter - Installation guide

Place the starter flywheel flange on the flywheel by aligning the six locator pins.

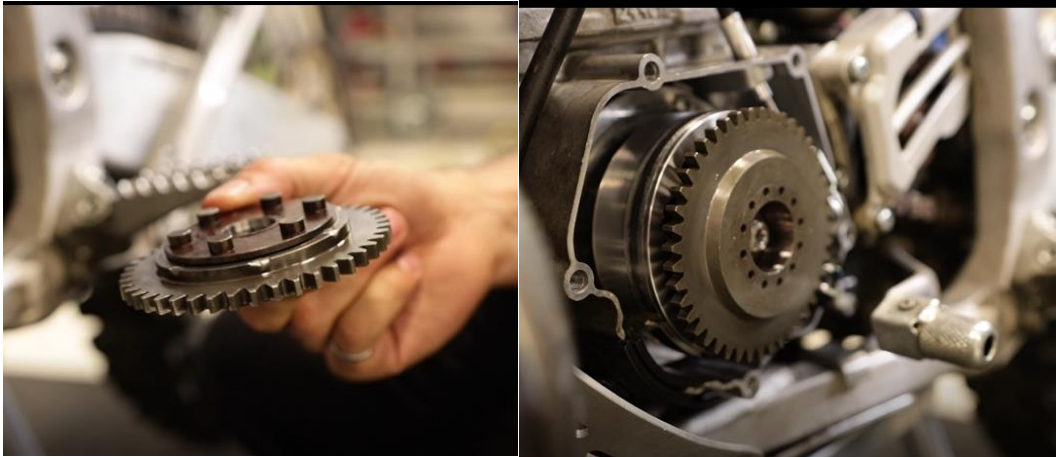

Place the main ring gear on the flange by rotating it clockwise while you push it on.

Put the needle bearing in the middle and insert the bolting unit.

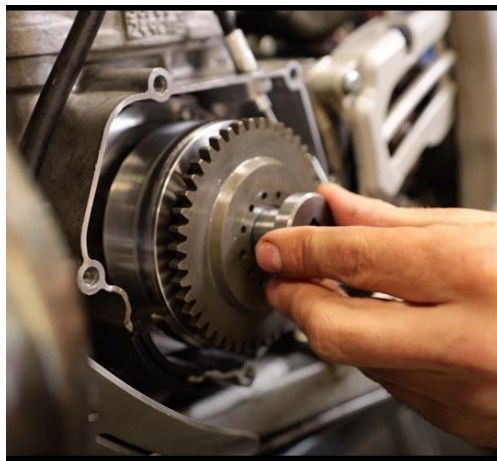

Using the gear holding tool supplied and a 1/2in torque wrench, torque the bolting unit to 40 ft-lb.



PANTHERA MOTORSPORTS

YZ250-YZ250X Electric starter - Installation guide

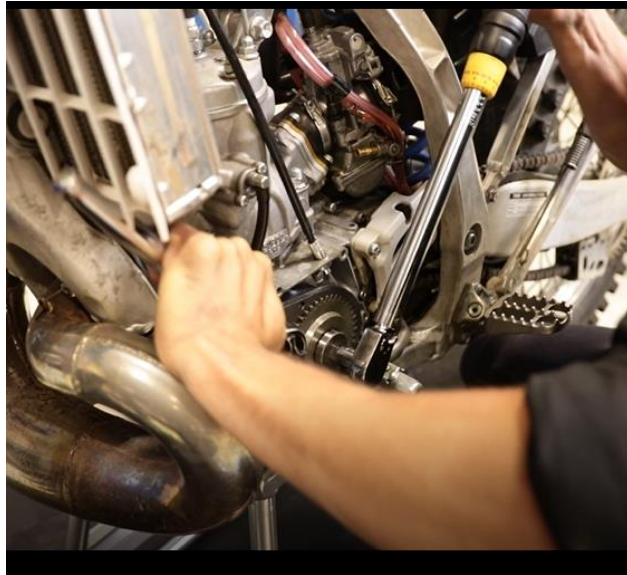

Make sure the main gear is still rotation freely clockwise and locking counterclockwise.

To ensure proper installation, measure the distance of the ring gear face to the gasket surface on the engine. Some cranks can be out of specifications or have been re-machined due to previous damages to crankshaft taper. If the flywheel doesn't sit at proper distance, it could damage the stator or prevent the starter gears from spinning. Push the gear toward the engine as much as it can and measure distance to engine gasket surface. The tolerance for the gear distance is 17.0 to 18.5.

!!! Make sure that the clutch actuator arm has clearance from the flywheel trigger bump, if too close, slightly bend the clutch actuator away.

[Starter housing installation](#)

To ensure a proper sealing of the starter housing, put silicones on the stator rubber boot area.





PANTHERA MOTORSPORTS

YZ250-YZ250X Electric starter - Installation guide

If you are running the starter without charging system, you will need to put the supplied steel shim with two gaskets. To make the installation easier, you can silicone the two gaskets on each side of the steel shim so they all stay together.

Unbolt the small gear cap of the starter housing with a 4mm allen and remove the two starter gears.

Install the housing on the engine with the proper gasket and ensure the housing central bearing is sliding on the flywheel bolting unit. Hold the cover in place and bolt it with the 5 allen cap screw. With a 5mm, torque the cover housing to 90 in-lb.

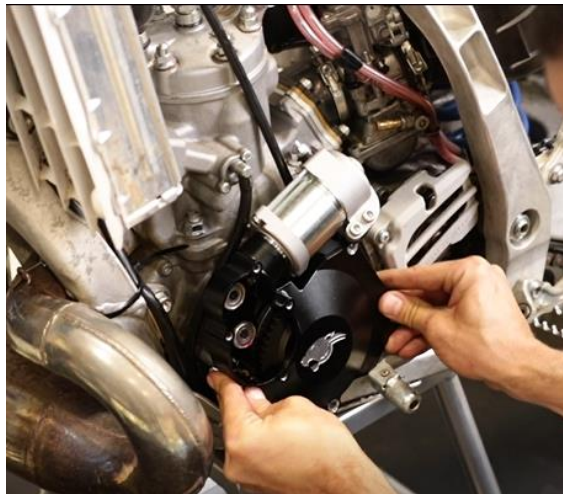

Make sure the main gear is still spinning freely clockwise.

Pour 300ml of ATF type F oil inside the starter housing.

Place the two small gears back, starting by the upper one. The second one will require meshing top and bottom gear at the same time. If gear doesn't want to mesh in, rotate the gear one tooth at a time till meshing is found.

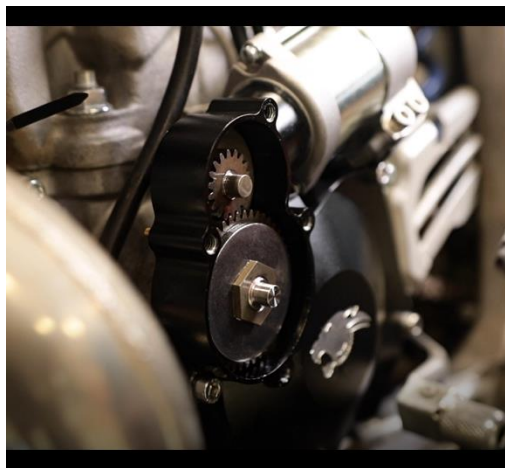



PANTHERA MOTORSPORTS

YZ250-YZ250X Electric starter - Installation guide

Place gear cap and its gasket back on and bolt it on with the 4 button heads. Use blue Loctite and torque to 90 in-lb.

The housing is equipped with a pressure vent at the back made to run a hose to a high point on the motorcycle, at least one feet higher than the housing. Place the hose so that its end points down and no water enters in it.

Starter and battery connection

Run the black ground wire in between the starter motor and the housing. Bolt the ground terminal to the left side bolt of the starter mount.

Connect the red wire to the starter motor terminal using a 10mm wrench.

Install the battery in the battery box, making sure the + and – are properly located. Secure the battery with the supplied rubber band. The 8 cells box supplied is designed for an **Antigravity AG-801** battery and the 4 cells box for the Antigravity SC-1.



Connect the harness to the battery, always connect the positive (red) first.

Once wires placed properly, tight the two nuts on the relay with at 10mm socket.

Tank and seat re-install

Re-install the fuel tank on and make sure none of the connectors are interfering. Bolt the tank back in place.

Chassis bolt torque is 86 in-lb and guard bolts torque is 51 in-lb.



PANTHERA MOTORSPORTS

YZ250-YZ250X Electric starter - Installation guide

Re-install the chassis to tank rubber band.

Reconnect the fuel line and slide the collar back on.

There is a plastic fin underneath the seat that will then be used to cut the rubber strap that holds the battery. We have supplied you with a u-shaped rubber to glue on the fin and project the strap.

Slide the seat on and secure with the 2 bolts. Torque to 13 ft-lb.

PRESS THE BUTTON AND GO HAVE FUN !!

User note: We often get asked if the whining sound at the engine shut off is normal. It is. When the engine comes to a stop, the compression pushes it backward a quarter turn and that makes the electric motor spin back a few turns. The gear sound is perfectly normal.

Maintenance

It is recommended to flush the oil after the first ride to eliminate particles generated by the gears first meshing and break in. Taking cover off to remove all particles is recommended versus only using the drain plug.

On a normal basis, change the oil at the same time as transmission oil.

Flywheel puller

The supplier gear holder to torque the flywheel also acts like a flywheel puller





PANTHERA MOTORSPORTS

YZ250-YZ250X Electric starter - Installation guide

Annexe 1 YZ250 Wiring diagram

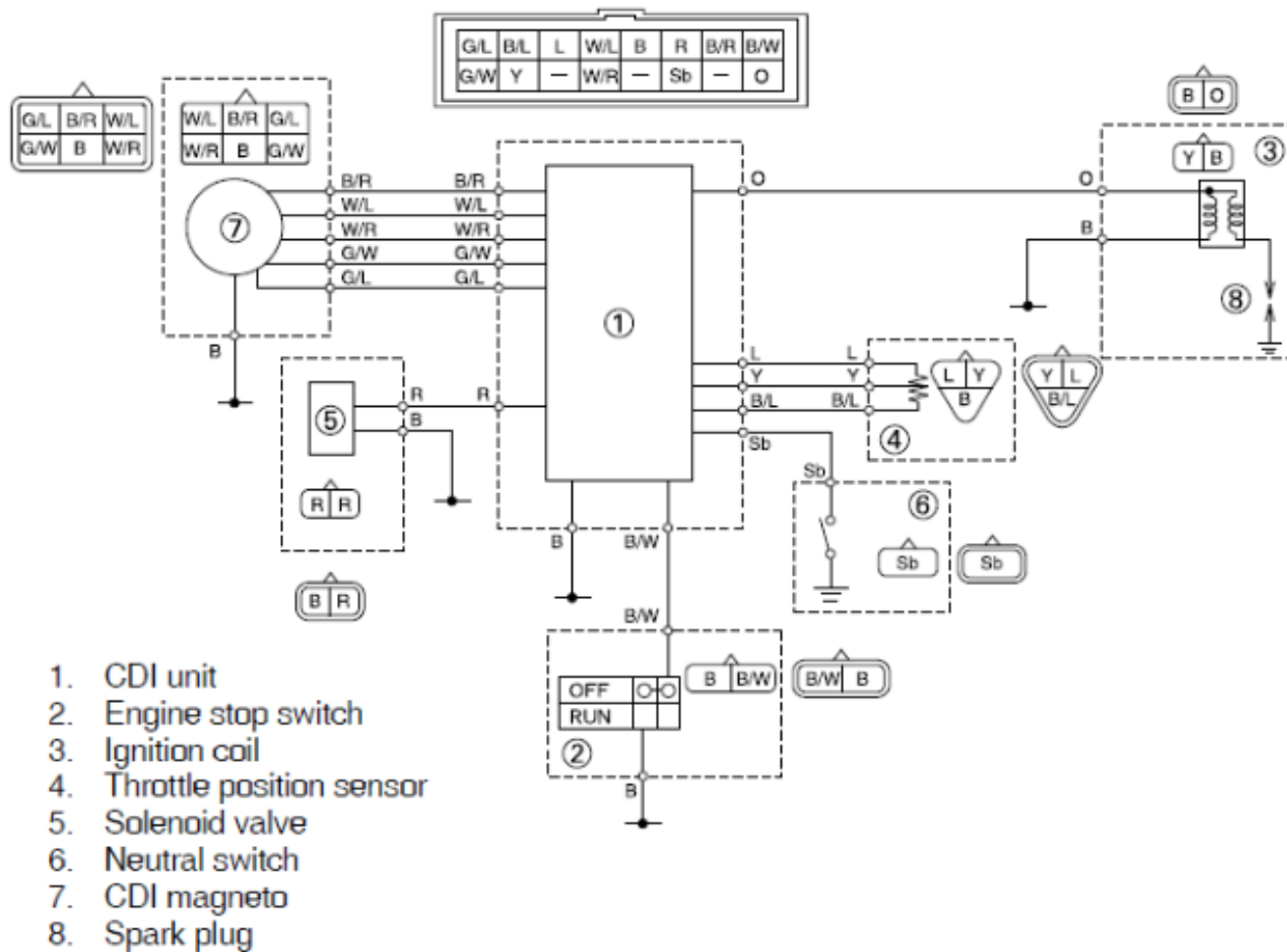



PANTHERA MOTORSPORTS

YZ250-YZ250X Electric starter - Installation guide

Annexe 2 Electric starter system wiring diagram

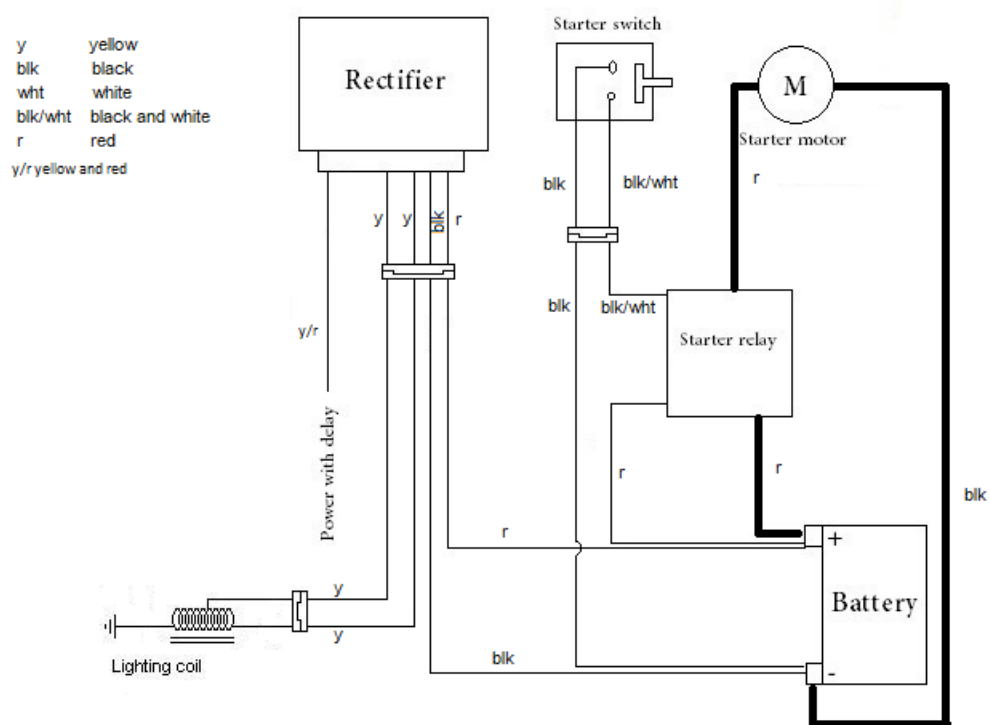

*Power with delay (yellow-red wire) is a 12V current source that only charges few seconds after the engine is started



PANTHERA MOTORSPORTS

YZ250-YZ250X Electric starter - Installation guide

Returns and Exchanges

General:

All returns must be postmarked no later than 10 days from the original customer shipment date. Returns and exchanges must be in new condition and must include all instructions and original packing material. Customer pays all return shipping charges. Include a copy of your packing list and authorization number with all returns.

Original shipping and handling charges are not refundable. Returns must be preauthorized by us and are subject to a 20% re-stocking fee. These amounts will be deducted from the original amount billed and the remaining balance will be credited to the original credit card or paypal account.

Incorrect Item:

If you received an incorrect item, we must be notified within 10 days of receipt of the shipment so that no extra charges will be incurred. We will replace incorrect items and pay the additional shipping charge. No returns of items will be accepted beyond 21 days of the original shipment date.

Return Shipping Instructions:

Return via prepaid mail only. Insure shipment for full value of purchase. Use original packaging. We are not responsible for packages lost during return shipping.

Return/Exchange Instructions:

Enclose a copy of your packing list along with detailed return/exchange instructions.

All returns require prior authorization by e-mailing us at info@pantheramotorsports.com . All return shipping charges will be the responsibility of the customer. No returns on items under \$30.00 will be approved. Items must be returned within 90 days of the original order date in the original packaging with the labels intact.



PANTHERA MOTORSPORTS

YZ250-YZ250X Electric starter - Installation guide

Warranty Items:

All merchandise manufactured by Panthera Motorsports has a warranty against manufacturing defects for a period of one (1) year from the date of original shipping. Warranty is limited to the repair or replacement of defective products. There is no warranty for normal wear and tear, any type of crash. Panthera Motorsports reserves the right to repair, replace or issue a Panthera credit for defective product at its discretion. Credits are valid for a period of one (1) year from issuance. No credit will be issued for labor or other costs incurred beyond the value of the original product. Product returned as a warranty after having been used, if found to be defective, is not valued at the full purchase price. A depreciated value will be estimated for used product. Warranty excludes product that has been modified or where the product was improperly installed, abnormally used or misused. This limited warranty is in lieu of all other guarantees or warranties implied or expressed. This includes, without limitation, any warranties or merchantability and fitment for a particular purpose. We make no warranty as to products distributed by Panthera Motorsports, expressed or implied. We will, however, pass on all warranties made by the manufacturer, who has sole responsibility for performing such warranties. A return authorization number must be issued by Panthera Motorsports before product is returned. Returns must be sent back to Panthera Motorsports freight prepaid. Proof of purchase, such as a copy of the original invoice, must accompany all warranty claims. Warranties will be honored to the direct purchaser only.